



MULTI GRIP PULL-UP SYSTEM

SG5004

YOUR SPECIALIST IN THE FIELD OF CALISTHENICS & BODYWEIGHT TRAINING

TECHNICAL DRAWING

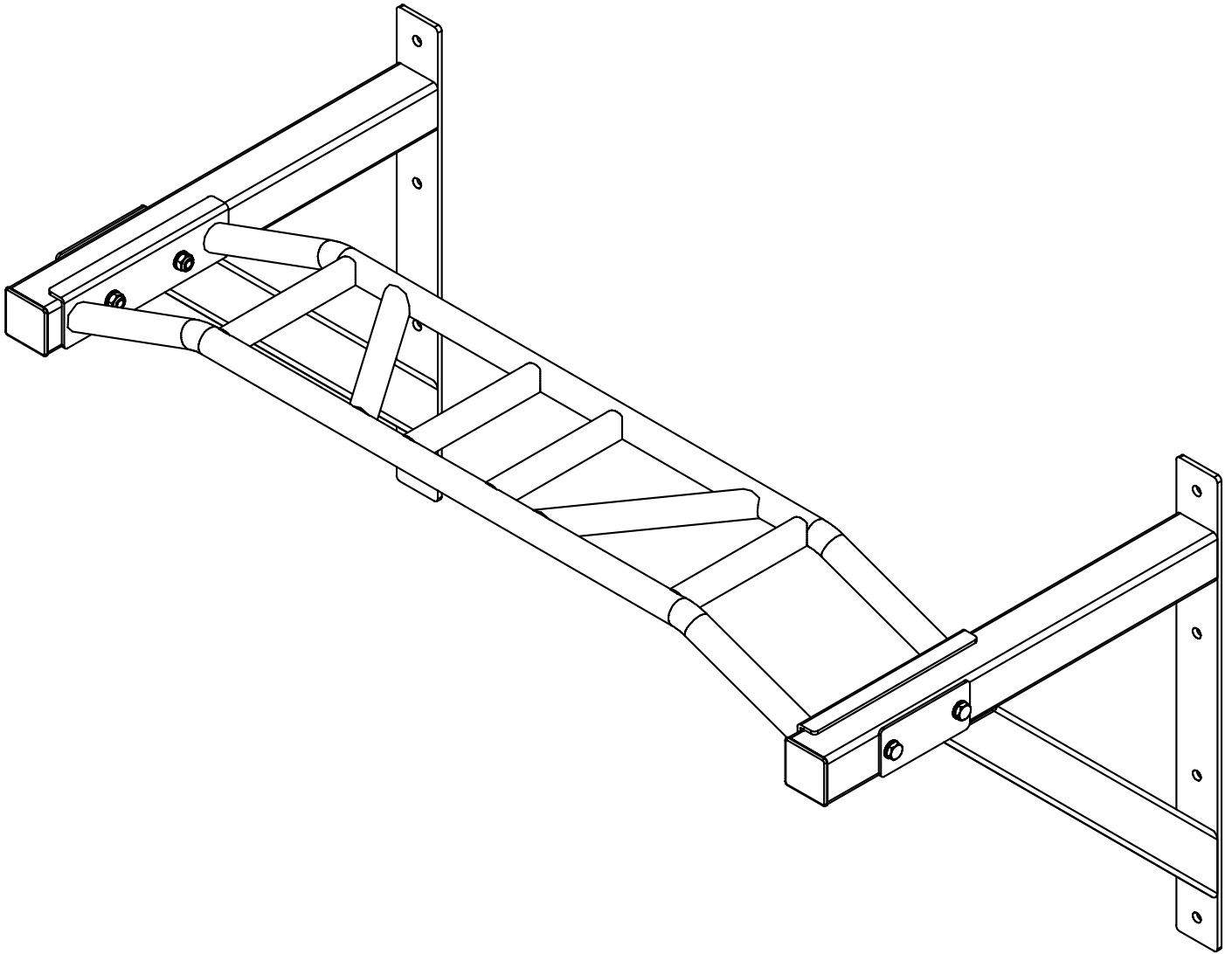

SAFETY INSTRUCTIONS

SAFETY FIRST

We know you're excited to start using your equipment and get exercising, but taking a moment to ensure your safety is crucial. A brief lapse in attention or skipping simple safety precautions can lead to accidents. Here's how to stay safe:

A. FOLLOW ASSEMBLY INSTRUCTIONS

Assemble the equipment as per the instructions using only the provided parts listed in the parts list. Before you start, verify that you have received everything as per the packing list.

B. READ THE MANUAL

Thoroughly read, study, and understand the Owner's Manual and all warning labels on the product. Familiarize yourself and others with the proper operation and workout recommendations. This information is available in the Owner's Manual and from your local retailer.

C. RETAIN THE MANUAL

Keep the Owner's Manual handy and ensure all warning labels remain legible and intact. If needed, replacement manuals and labels are available from your local retailer.

D. GET ASSISTANCE

It's a good idea to have someone help you with the assembly of this product.

E. CONSULT YOUR DOCTOR

Before starting any exercise program, consult with your physician and consider undergoing a complete physical examination.

F. SUPERVISE CHILDREN

Use discretion when children are present to ensure they stay safe around the equipment.

G. AVOID MOVING PARTS

Keep hands, limbs, loose clothing, and long hair away from moving parts to prevent injury.

H. LIFT SMART

Do not attempt to lift more weight than you can safely handle.

I. KNOW YOUR LIMITS

Work within your recommended exercise level and do not push yourself to exhaustion. If you feel any pain or discomfort, stop your workout immediately.

J. INSPECT REGULARLY

Regularly check the equipment for signs of wear, loose hardware, or cracks in welds. Do not use the machine if any issues are found until they are repaired or replaced.

K. KEEP AREA CLEAR



Do not place any sharp objects around the equipment to avoid damage or injury.



PARTS LIST

CHECK THE BOX

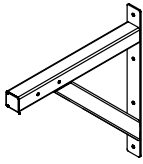
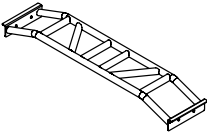
Before you start installing the StreetGains Multi Grip Pull-up System, check carefully whether the following parts are

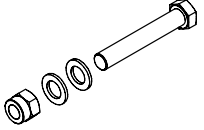
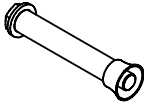
Bracket	Bar	Splint	M10*80 Bolt, Nut, Washer
<p>①</p>  <p>2 PCS</p>	<p>②</p>  <p>1 PC</p>	<p>③</p>  <p>2 PCS</p>	<p>④</p>  <p>4 PCS</p>
M12*100 Expansion Bolt			
<p>⑤</p>  <p>8 PCS</p>			

INSTALLATION

IMPORTANT WARNING AND ADVICE

- The pull-up bar comes with standard expansion bolts. These may not be suitable for every wall type.
- Always consult a professional to ensure your wall is strong enough to support the weight of the pull-up bar and to determine the appropriate mounting hardware for your specific wall type.

CHOOSE THE LOCATION

- Select a suitable location for your pull-up bar. Ensure there is enough space around the bar for you to perform pull-ups without obstruction.
- If mounting on drywall, use a stud finder to locate the studs. Mark the stud locations with a pencil.

ASSEMBLING THE PULL-UP BAR

- Align the two brackets (1) with the designated mounting points on the splint (3) and bar (2). Ensure they are positioned correctly and symmetrically on both ends of the bar.
- Insert one M10x80 bolt (4) through the hole in one bracket and into the corresponding hole in the bar.
- Use a wrench or a socket set size 17 mm to tighten the bolt and nut securely.
- Repeat this process for the remaining three bolts, ensuring each bracket is firmly attached to the bar with two bolts.
- Ensure the brackets are securely fastened and there is no wobbling or movement.



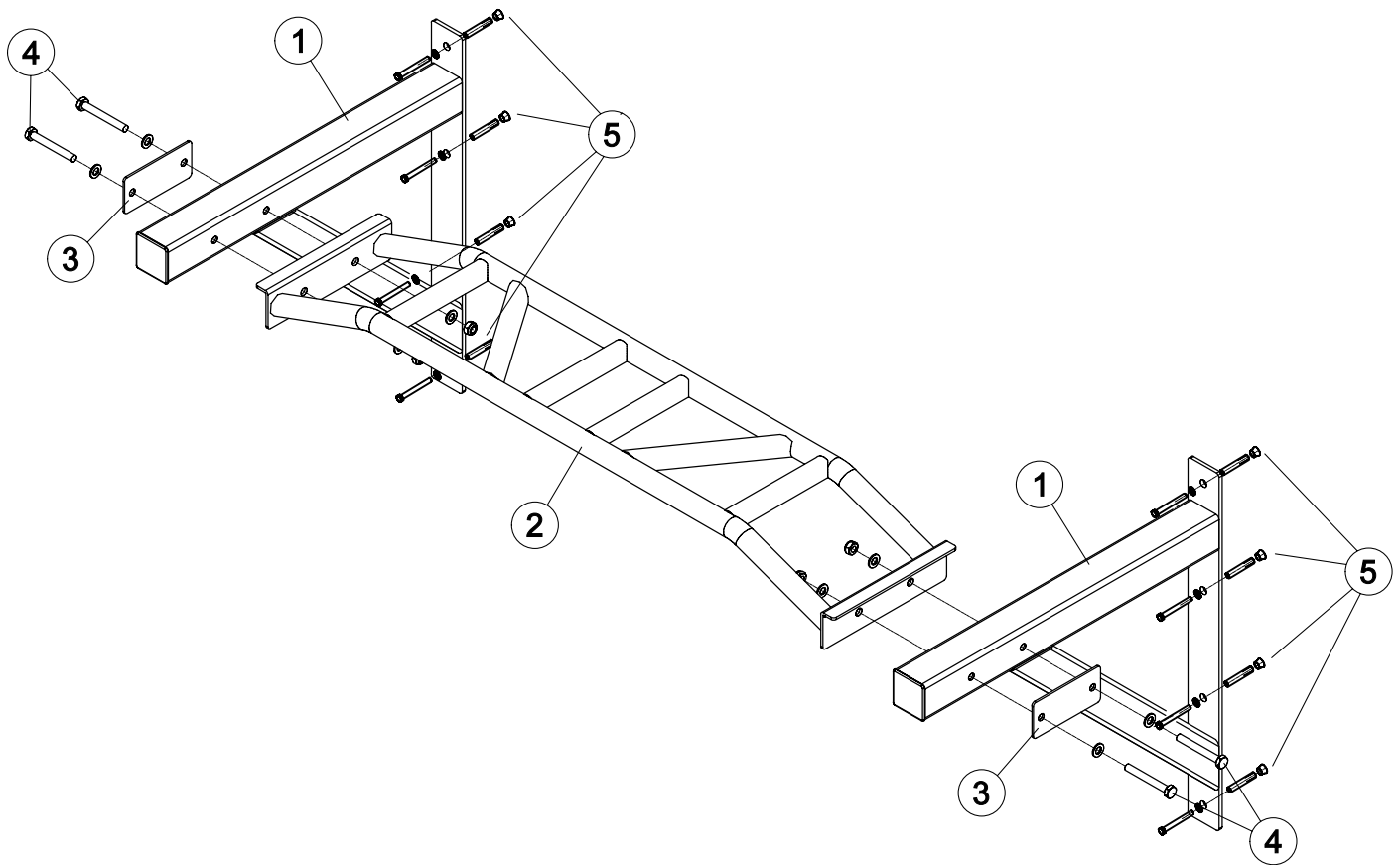

MARK THE MOUNTING POINTS

- Hold the pull-up bar against the wall at the desired height. Use a level to ensure it is straight.
- Mark the mounting points on the wall through the holes in the bracket with a pencil.

DRILL HOLES

- Put on your safety glasses.
- Using the appropriate drill bit for your wall type, drill pilot holes at the marked points. Ensure the holes are deep enough to accommodate the mounting bolts.
- If you are using the supplied expansion bolts, start by pre-drilling with a smaller drill bit. Then, use a 16 mm drill bit to finish drilling the holes.
- Remove any dust and debris from the holes using a brush, vacuum, or compressed air.
- For brick or concrete walls, use a masonry drill bit. For drywall, ensure you are drilling into studs.



MOUNT THE PULL-UP BAR

- Tap the expansion bolts (5) into the holes until they are flush with the surface. You may need to use a hammer for this step.
- Carefully unscrew the bolts from the expansion tubes, ensuring the tubes remain in place within the wall.
- Position the pull-up bar against the wall, ensuring it is aligned with the drilled holes.
- Insert the bolts back into the expansion tubes and tighten them securely using a wrench or a socket set size 19 mm.
- Make sure each bolt is firmly fastened to ensure the stability of the pull-up

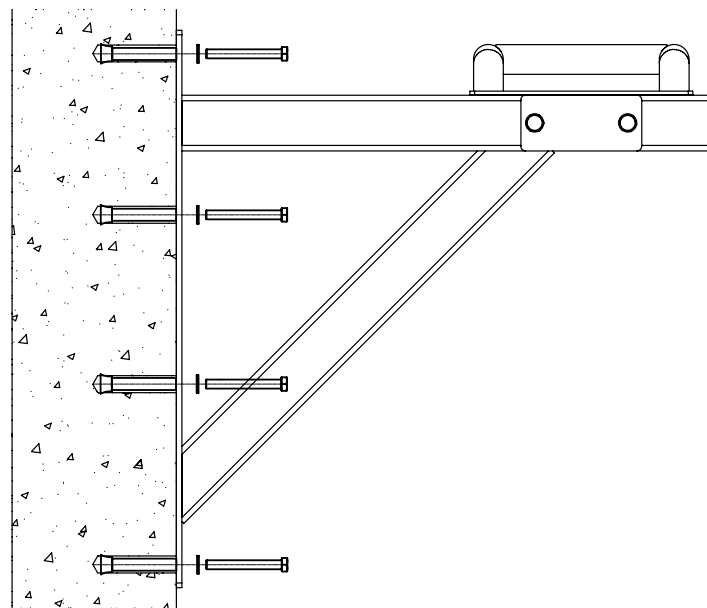

TEST THE INSTALLATION

- Carefully apply pressure to the pull-up bar to ensure it is securely mounted.
- Gradually increase the pressure to simulate a pull-up. If the bar feels secure, perform a slow and controlled pull-up to test its stability.

TIPS

- Double-check all measurements and levels before drilling.
- Regularly inspect the pull-up bar and mounting hardware for any signs of wear or loosening.





NEED OUR HELP?

**CONTACT OUR CUSOTMER SERVICE
AT INFO@STREETGAINS.NL**



[@STREETGAINS.OFFICIAL](https://www.instagram.com/streetgains.official)



[@STREETGAINS.OFFICIAL](https://www.tiktok.com/@streetgains.official)



[@STREETGAINS.OFFICIAL](https://www.facebook.com/streetgains.official)